

24V 6A PWM STEP-UP DC-DC CONVERTER

GENERAL DESCRIPTION

The SLM6260 devices are high-performance, fixed frequency, current-mode PWM step-up DC/DC converters that incorporate internal power MOSFETs. The SLM6260 includes an integrated 50-mΩ power switch that supports peak currents of up to 6A. The device is capable of providing an output voltage up to 24V.

The SLM6260 uses peak current control topology to regulate the output voltage. In moderate to heavy load condition, the SLM6260 works in the pulse width modulation (PWM) mode. In light load condition, the device works in the pulse frequency modulation (PFM) mode to improve the efficiency.

The SLM6260 utilizes simple external loop compensation allowing optimization between component size, cost and AC performance across a wide range of applications. Additional functions include an externally programmable soft-start function for easy inrush current control, internal over-voltage protection (OVP), cycle-by-cycle current limit protection, under voltage lock-out and thermal shutdown.

The SLM6260 is available in the small SOIC8-EP package.

FEATURES

- Input Voltage Range: 2.7 to 5.5V
- Adjustable Output Voltage Up to 24V
- 6A Switch Current
- Up to 85% Efficiency at $V_{IN} = 4.2V$, $V_{OUT} = 12V$, and $I_{OUT} = 1.0A$
- Internal 24V 50-mΩ Power MOSFET
- 0.1μA Current into VIN Pin during Shutdown
- 800kHz Frequency
- Built-in Over-Voltage Protection (OVP)
- Open Protection
- Programmable Soft-Start Function
- Thermal Shutdowns
- Under-Voltage-Lockout
- Cycle-by-Cycle Overcurrent Protection
- SOIC8-EP Package

APPLICATIONS

- Battery-Powered Equipment (Bluetooth™ Speaker; E-Cigarette; Quick Charge Power Bank)
- Portable POS Terminal
- TFT LCD Monitors
- Set-Top Boxes
- DSL and Cable Modems and Routers

TYPICAL APPLICATION CIRCUIT

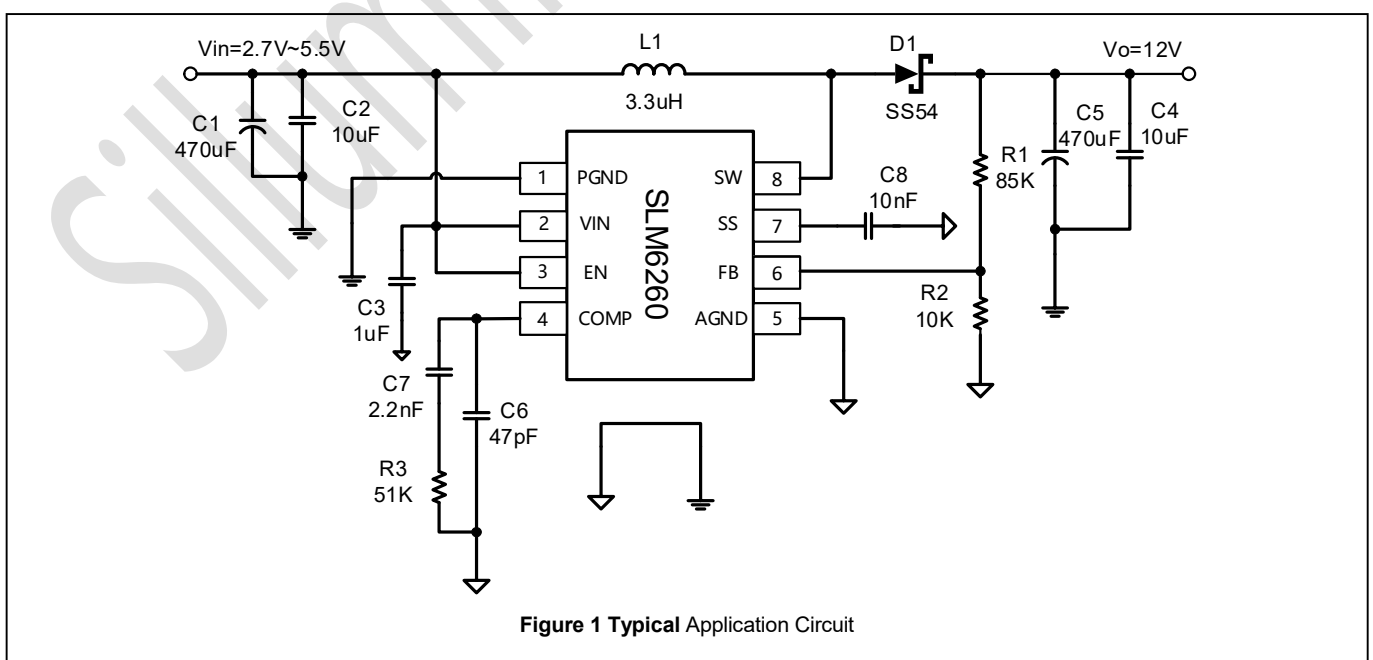

PIN CONFIGURATION

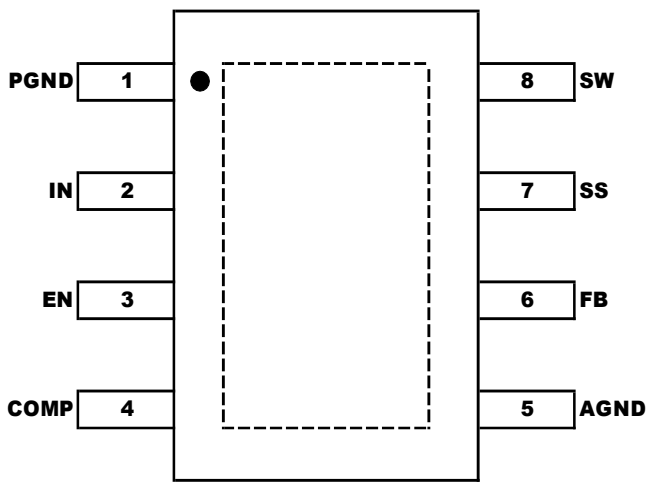
Package	Pin Configuration (Top View)
SOIC8-EP	

PIN DESCRIPTION

No.	Pin	Description
1	PGND	Power Ground
2	IN	Supply Input
3	EN	Enable Control. Connect to a logic high level to enable the IC. Connect to a logic low level to disable the IC. When unused, connect EN pin to IN (do not leave pin floating).
4	COMP	Error Amplifier Compensation Node
5	AGND	Analog Ground
6	FB	Feedback Input. Connect this pin a resistor divider from the output to set the output voltage. FB is regulated to 1.262V.
7	SS	Soft Start Control Input. Connect a capacitor from this pin to Ground to set soft-start timing duration. SS is discharged to ground in shutdown. SS may be left unconnected if soft start is not desired.
8	SW	Switch Output. Connect this pin to the inductor and the schottky diode. To minimize EMI, minimize the PCB trace path between this pin and the input bypass capacitor.
-	Exposed Pad	Connected to Ground

ORDERING INFORMATION

Industrial Range: -40°C to +125°C

Order Part No.	Package	QTY
SLM6260CB-13GTR	SOIC8-EP	2500/Reel
SLM6260CB-GT	SOIC8-EP	100/Tube

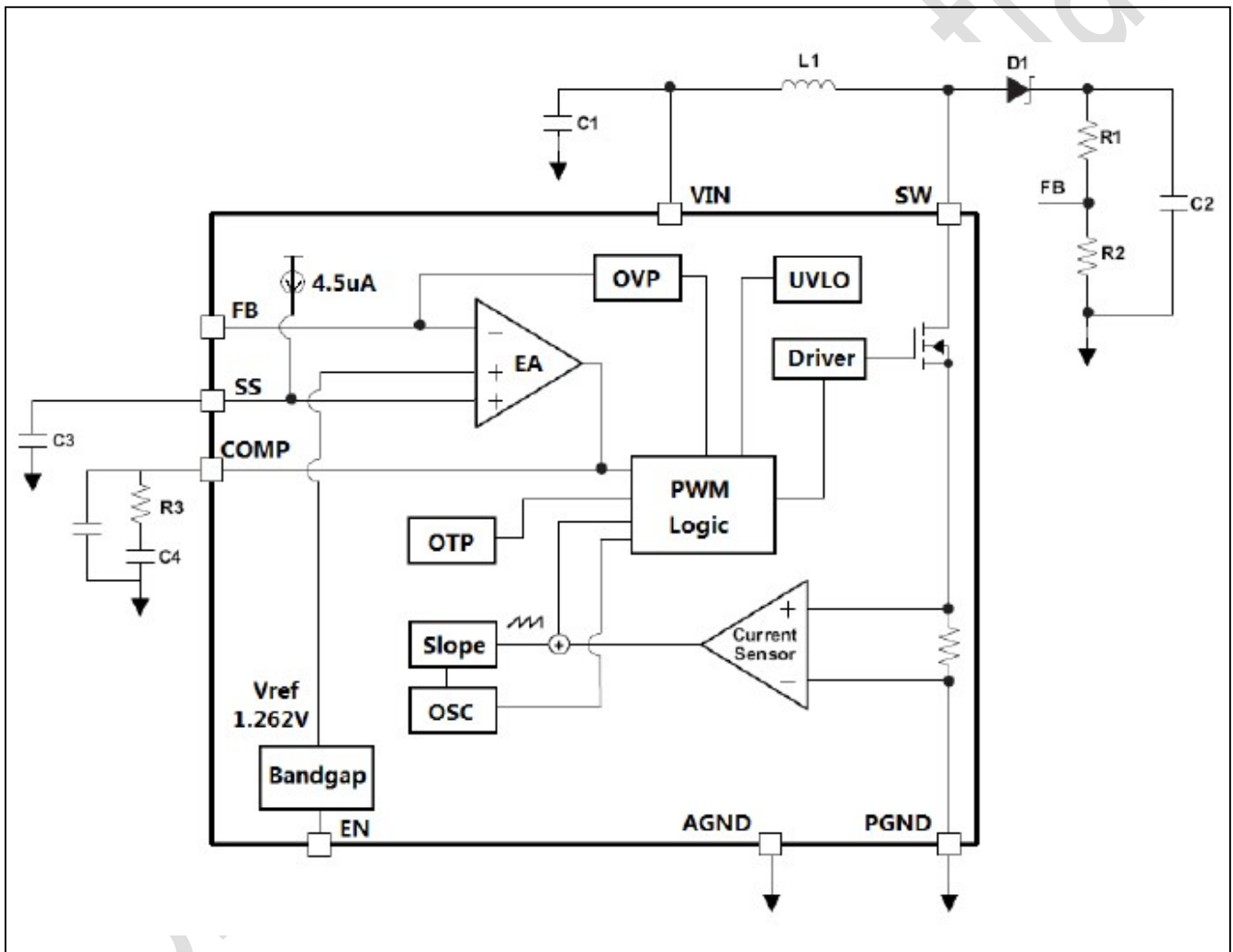
FUNCTIONAL BLOCK DIAGRAM

ABSOLUTE MAXIMUM RATINGS

SW to Ground	-0.3V ~ 28V	
V _{IN} , EN, FB, SS, COMP to Ground	-0.3V ~ 6.5V	
Continuous SW Current	Internally Limited	
Total power dissipation, P _{TOT}	1.5w (T _s ≤ 100°C)	
Maximum junction temperature, T _{JMAX}	150°C	
Storage temperature range, T _{STG}	-65°~+150°C	
Operating temperature range, T _A	-40°C~+125°C	
Package Thermal Resistance	Junction to Ambient, R _{th-JA}	60 °C/w
	Junction to Case, R _{th-JC}	15 °C/w
ESD (HBM)	2000 V	
ESD (CDM)	200 V	
ESD (FICDM)	1500 V	
Latch-up	+/- 100mA	

Note:

Stresses beyond those listed under "Absolute Maximum Ratings" may cause permanent damage to the device. These are stress ratings only and functional operation of the device at these or any other condition beyond those indicated in the operational sections of the specifications is not implied. Exposure to absolute maximum rating conditions for extended periods may affect device reliability.

ELECTRICAL CHARACTERISTICS (TBD)

Test condition is T_A = -40°C ~ +125°C. Typical values are at T_A = 25°C, unless otherwise specified.

Symbol	Parameter	Condition	Min.	Typ.	Max.	Unit
V _{IN}	Input voltage operation range		2.7		5.5	V
UVLO	Under voltage lockout threshold	V _{IN} Rising		2.5		V
	Under voltage lockout hysteresis			200		mV
I _Q	Chip quiescent current	V _{IN} =3.6V, V _{FB} =1.4V, Non-switching		0.30	0.35	mA
		V _{IN} =3.6V, V _{FB} =1.0V, Switching		3	5	
I _{SHDN}	Supply current in shutdown	EN=GND		0.1	1.0	uA
f _{REQ}	Switching frequency			800		kHz
DC	Maximum duty cycle		90			%
V _{FB}	Feedback voltage		1.23	1.26	1.29	V
I _{FB}	Feedback input current			0	80	nA
LNR	Feedback voltage line regulation	V _{FB} from 2.7V to 5.5V		0.05	0.15	%/V
I _{CL}	Switching peak current limit	V _{IN} =3.6V, Duty cycle = 70%	5.5	6.0		A
R _{DSON}	Switching ON resistance	V _{IN} =3.6V, V _{SW} =12V, Duty cycle = 70%		50		mΩ
I _{SW}	Switch leakage current	V _{SW} =12V, EN=GND			15	uA
I _{SS}	Soft start pin bias current	V _{SS} =1.2V	2.0	4.5	7.0	uA
V _{IH}	EN pin logic high		1.4			V
V _{IL}	EN pin logic low				0.4	V
R _{EN}	EN pull down resistor			1		MΩ
T _{SD}	Thermal shutdown temperature			150		°C
T _{SD_HYS}	Thermal shutdown hysteresis			15		°C

APPLICATION INFORMATION

The SLM6260 are highly efficient step-up DC/DC converters that employ a current mode, fixed frequency pulse-width modulation (PWM) architecture with excellent line and load regulation. The SLM6260 operate at constant switching frequency under medium to high load current conditions. At light loads, these devices operate in a pulse-skipping mode in order to improve light-load efficiency.

Soft-Start

The SLM6260 both offer a programmable soft-start function which minimizes inrush current during startup. The soft-start period is programmed by connecting a 10nF capacitor between SS and Ground. Operation of the soft-start function is as follows: when the IC is disabled, SS is actively discharged to Ground. Upon enabling the IC, CSS is charged with a 4.5μA current so that the voltage at SS increases in a controlled manner. The peak inductor current is limited by the voltage at SS, so that the input current is limited until the soft-start period expires, and the regulator can achieve its full output current rating.

Setting the Output Voltage

The both feature external adjustable output voltages of up to 24V. To program the output voltage, simply connect a resistive voltage divider between the output, FB, and GND, with resistors set according to the following equation:

$$R_1 = R_2 \times \left[\left(\frac{V_{OUT}}{V_{FB}} \right) - 1 \right]$$

where $V_{FB}=1.26V$

Rectifier Selection

For optimal performance, the rectifier should be a Schottky rectifier that is rated to handle both the output voltage as well as the peak switch current.

Open Voltage Protection

The features internal automatic over-voltage protection, when feedback voltage is higher than 115%.

Overcurrent Protection

The SLM6260 has a cycle-by-cycle overcurrent limit protection that turns off the power switch once the inductor current reaches the overcurrent limit threshold. The PWM circuitry resets itself at the beginning of the next switch cycle. During an

overcurrent event, the output voltage begins to droop as a function of the load on the output.

$$V_{OUT} = \frac{V_{IN} \times \left(I_{CL} - \frac{I_{RIPPLE}}{2} \right) \times \eta}{I_{OUT}}$$

where

- V_{OUT} is the output voltage of the boost regulator.
- I_{OUT} is the output current of the boost regulator.
- V_{IN} is the input voltage of the boost regulator.
- I_{CL} is the input switching peak current limit of the boost regulator.
- I_{RIPPLE} is the inductor ripple current of the boost regulator.
- η is the power conversion efficiency.

Open Circuit Protection

Once the outputs achieve regulation, if the voltage at FB falls below 0.2V the controller will automatically disable, preventing the controller from running open-loop and potentially damaging the IC and load.

Shutdown

Drive EN low to disable the IC and reduce the supply current to just 0.1μA. As with all non-synchronous step-up DC/DC converters, the external Schottky diode provides a DC path from the input to the output in shutdown. As a result, the output drops to one diode voltage drop below the input in shutdown.

The SLM6260 both feature integrated thermal overload protection. Both devices are automatically disabled when their junction temperatures exceed +150°C, and automatically re-enable when the die temperature decreases by 15°C.

TYPICAL OPERATING CHARACTERISTICS

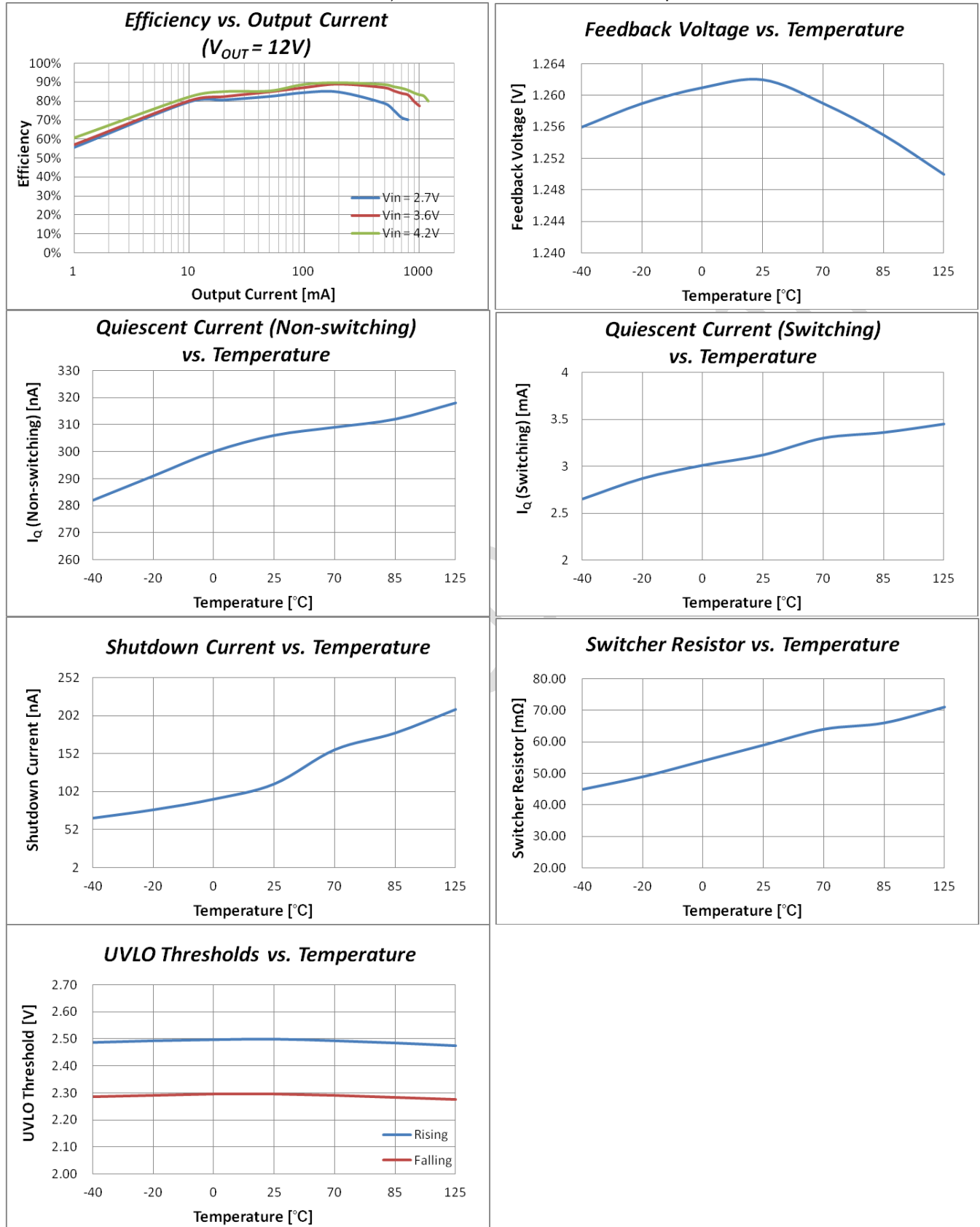
 Test condition is $T_A = 25^\circ\text{C}$, $V_{IN} = V_{EN} = 5.0\text{V}$, $V_{FREQ} = 0\text{V}$, unless otherwise specified.

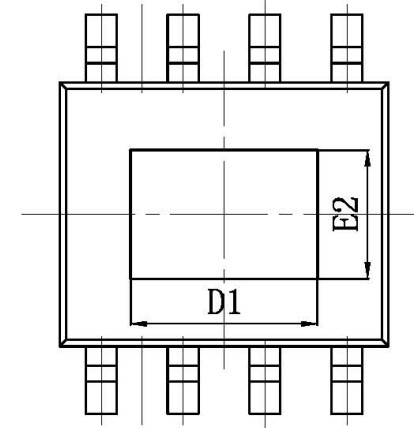
PACKAGE INFORMATION
SOIC8-EP

SYMBOL	MILLIMETER		
	MIN	NOM	MAX
A	—	—	1.75
A1	0.05	—	0.15
A2	1.30	0.43	1.50
A3	0.60	0.65	0.70
b	0.39	—	0.48
b1	0.38	0.41	0.43
c	0.21	—	0.26
c1	0.19	0.20	0.21
D	4.70	4.90	5.10
E	5.80	6.00	6.20
E1	3.70	3.90	4.10
e	1.27BSC		
h	0.25	—	0.50
L	0.50	—	0.80
L1	1.05BSC		
θ	0	—	8°
D1	3.20	—	3.40
E2	2.31	—	2.51
L/P载体尺寸 (mm)	90*90	95*130	

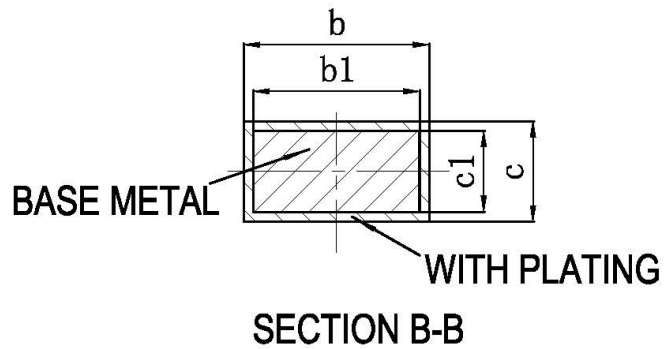
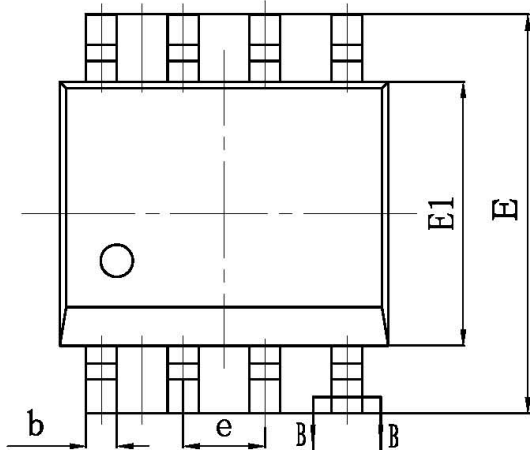
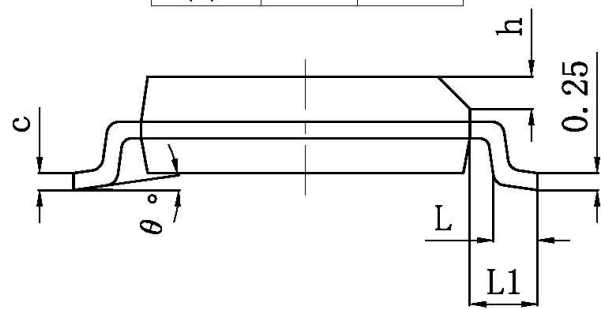
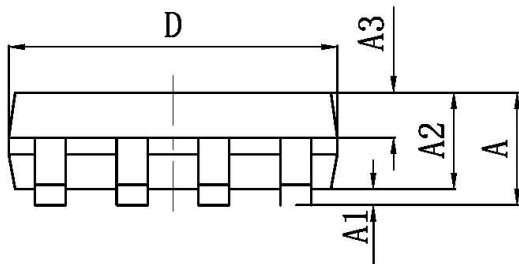

Note: All dimensions in millimeters unless otherwise stated.

Revision History

Note: page numbers for previous revisions may differ from page numbers in current version

Page or Item	Subjects (major changes since previous revision)
Rev 1.0 datasheet, 2019-9-2	
Whole document	New company logo released
Page 1	Change typical application circuit

IMPORTANT NOTICE

Sillum Semiconductor Co., Ltd. and its subsidiaries (SILLUMIN) reserve the right to make corrections, enhancements, improvements and other changes to its semiconductor products and services per JESD46, latest issue, and to discontinue any product or service per JESD48, latest issue. Buyers should obtain the latest relevant information before placing orders and should verify that such information is current and complete. All semiconductor products (also referred to herein as “components”) are sold subject to SILLUMIN’s terms and conditions of sale supplied at the time of order acknowledgment.

SILLUMIN warrants performance of its components to the specifications applicable at the time of sale, in accordance with the warranty in SILLUMIN’s terms and conditions of sale of semiconductor products. Testing and other quality control techniques are used to the extent SILLUMIN deems necessary to support this warranty. Except where mandated by applicable law, testing of all parameters of each component is not necessarily performed.

SILLUMIN assumes no liability for applications assistance or the design of Buyers’ products. Buyers are responsible for their products and applications using SILLUMIN components. To minimize the risks associated with Buyers’ products and applications, Buyers should provide adequate design and operating safeguards.

SILLUMIN does not warrant or represent that any license, either express or implied, is granted under any patent right, copyright, mask work right, or other intellectual property right relating to any combination, machine, or process in which SILLUMIN components or services are used. Information published by SILLUMIN regarding third-party products or services does not constitute a license to use such products or services or a warranty or endorsement thereof. Use of such information may require a license from a third party under the patents or other intellectual property of the third party, or a license from SILLUMIN under the patents or other intellectual property of SILLUMIN.

Reproduction of significant portions of SILLUMIN information in SILLUMIN data books or data sheets is permissible only if reproduction is without alteration and is accompanied by all associated warranties, conditions, limitations, and notices. SILLUMIN is not responsible or liable for such altered documentation. Information of third parties may be subject to additional restrictions.

Resale of SILLUMIN components or services with statements different from or beyond the parameters stated by SILLUMIN for that component or service voids all express and any implied warranties for the associated SILLUMIN component or service and is an unfair and deceptive business practice.

SILLUMIN is not responsible or liable for any such statements.

Buyer acknowledges and agrees that it is solely responsible for compliance with all legal, regulatory and safety-related requirements concerning its products, and any use of SILLUMIN components in its applications, notwithstanding any applications-related information or support that may be provided by SILLUMIN. Buyer represents and agrees that it has all the necessary expertise to create and implement safeguards which anticipate dangerous consequences of failures, monitor failures and their consequences, lessen the likelihood of failures that might cause harm and take appropriate remedial actions. Buyer will fully indemnify SILLUMIN and its representatives against any damages arising out of the use of any SILLUMIN components in safety-critical applications.

In some cases, SILLUMIN components may be promoted specifically to facilitate safety-related applications. With such components, SILLUMIN’s goal is to help enable customers to design and create their own end-product solutions that meet applicable functional safety standards and requirements. Nonetheless, such components are subject to these terms.

No SILLUMIN components are authorized for use in FDA Class III (or similar life-critical medical equipment) unless authorized officers of the parties have executed a special agreement specifically governing such use.

Only those SILLUMIN components which SILLUMIN has specifically designated as military grade or “enhanced plastic” are designed and intended for use in military/aerospace applications or environments. Buyer acknowledges and agrees that any military or aerospace use of SILLUMIN components which have not been so designated is solely at the Buyer’s risk, and that Buyer is solely responsible for compliance with all legal and regulatory requirements in connection with such use.

SILLUMIN has specifically designated certain components as meeting ISO/TS16949 requirements, mainly for automotive use. In any case of use of non-designated products, SILLUMIN will not be responsible for any failure to meet ISO/TS16949.

Please refer to below URL for other products and solutions of Sillum Semiconductor Co., Ltd.

www.sillum.com

Address: Room 604-2, Building 21A, No. 1158 Zhongxin Road, Songjiang, Shanghai, 201615 China

Copyright© 2019, Sillum Semiconductor Co., Ltd.